

DATA Sheet

Total Suspended Solids Systems



Model 711
Portable MLSS/ILA System



Model 7011A
Single Channel Analyzer



Series 7100/8000
Multi Channel/Parameter
DO/TSS Systems

Model 711 Portable MLSS/ILA System Features

- ◆ Two complete analyzers in one package (TSS & Interface Level)
- ◆ Microprocessor based
- ◆ Automatic ranging
- ◆ Simple, insitu calibration
- ◆ Electronic self-diagnostics
- ◆ Nine volt battery with automatic shutoff
- ◆ Waterproof, rugged housing

Models 7100/8000 Series Continuous System Features

- ◆ Microprocessor based electronics
- ◆ Automatic ranging
- ◆ Simple to use insitu calibration
- ◆ Menu driven text help screens
- ◆ Electronic self diagnostics
- ◆ Digital communications with isolation and surge protection
- ◆ Isolated current on voltage outputs
- ◆ Up to 2 set-point relays per channel
- ◆ User selectable calibration curves
- ◆ Backlit display (7110/7120/8000 Series)
- ◆ Menu driven text help screens
- ◆ Phased array source for automatic color compensation (Model 73B Sensor)
- ◆ Automatic ambient light compensation on all sensors
- ◆ NEMA 4X (IP65) enclosure

Continuous Monitoring and Control Solids Analyzers

The **Model 7011A Total Suspended Solids (TSS) Analyzer** is the tried and true performer that has buttressed the Royce line of solids analyzers for years. Still the most used TSS analyzer in the industry, the Model 7011A is the primary single channel offer in the Royce line of analyzers.

Specifications

Range:

Multiple Ranges:
0 - 10,000 up to 0 - 80,000 mg/l
(Sensor Dependent)

Standard Outputs:

4 - 20 mA or 0 - 1 VDC (Isolated)
RS-485 serial port (isolated and surge protected)

Standard Setpoints:

Two programmable setpoint relays
All relays are form C rated 250 VAC, 7 Amps resistive



Readout Device:

Harsh environment, 2.2 x 1.5 inch LCD digital display

Input Power:

Switch selectable 115/230 VAC, 60/50 Hz

Enclosure:

NEMA 4X (IP65) Fiberglass

Instrument Ambient Conditions:

Temperature: -10 to 50° C

With Heater: -40 to 50° C

Humidity: 0 to 100%

Analyzer Options:

NEMA 4X enclosure with quick disconnect for sensor

Rear Rail mounting kit

JB-93 junction box with quick disconnect for sensor

Weight:

5.5 Lbs (2.5 kg)

The **Series 7110/7120 Water Process Analyzer** is a single or dual channel solids monitoring system that offers the latest in digital communication while utilizing one or two Royce TSS sensors. Sensors do not have to be the same model.

The **Series 8000 Water Process Analyzer** can be made up to a 4-channel system that will incorporate up to any two TSS sensors plus two Dissolved oxygen sensors. While it can be purchased as a dual channel, 3-channel or 4-channel system, the sensor combinations are almost unlimited.

Series 7100 and 8000 Analyzer Specifications

Instrument Ambient Conditions:

Temperature: -10 to 50° C

Humidity: 0 to 100%

Input Power:

80 - 260 VAC, 60/50 Hz or 12 VDC

Outputs:

Four isolated 4 - 20 mA per analyzer
600 ohms maximum

Four Relays with programmable hysteresis per channel

10A resistive @ 250 VAC

RS-485 Standard

Optional Profibus PA or DP communication



Readout Device:

Harsh environment, four line, 20 Character backlit LCD digital display

Calibration:

Automatic, push-button for DO and In-Situ calibration to a known value for TSS

Enclosure:

NEMA 4X (IP65) Fiberglass

Weight:

5.5 Lbs (2.5 kg)

Multi-Parameter 8000 Analyzer/Sensor Specifications

Model 8120 -

For one DO 99/95 and one TSS sensor

Model 8130 -

For two DO99/95 and one TSS sensor
or two TSS sensors and one DO sensor 99/95

Model 8140 -

For two DO 99/95 and two TSS sensors

Model 8220 -

For one Model 96A DO sensor and one TSS sensor

Model 8230 -

For two Model 96A DO sensors and one TSS sensor
or one Model 96A DO sensor and two TSS sensors

Model 8240 -

For two Model 96A DO sensors and two TSS sensors

NOTE:

The **Model 96A** DO sensor is a Royce patented electrochemical self-cleaning DO sensor

Model 72A Low Range TSS Sensor

The **Model 72A** is for low ranges commonly experienced in effluent streams (0 - 1500 mg/l). It incorporates a unique automatic ambient light compensating technology that allows for clean water monitoring insitu, without requiring sample intake lines for reflection chambers. Automatic self cleaning is available.

Type:

Single Gap Optical

Range:

0 - 10 up to 0 - 1500 mg/l

0 - 5 up to 0 - 500 NTU

Resolution:

1 mg/l

Accuracy:

± 5% of reading or

± 5 mg/l, whichever is greater

Repeatability:

± 1% of reading or

± 2 mg/l, whichever is greater

Operating Limits:

Temperature: 0 - 50° C

Pressure: 0 - 50 PSIG

Size:

4.5 inches square

Weight:

5.5 Lbs (2.5 kg)

Construction:

Chemically resistant polyurethane optics in polyurethane housing

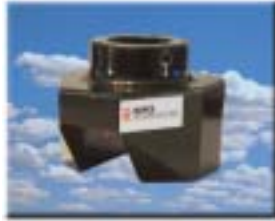

Model 72A Sensor Mounting

- ◆ The sensor cable is a 5 conductor shielded 22 AWG. It is available in 25 and 50 foot lengths as standard, or can be special ordered as required.
- ◆ A connector for quick disconnect to the monitor is available as an optional convenience on the sensor and analyzer. The connector option on the sensor is required when used with the JB-93 junction box.
- ◆ All Royce suspended solids sensors are equipped for an air or water jet cleaning.

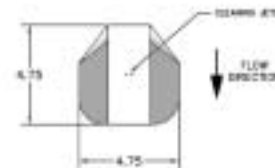
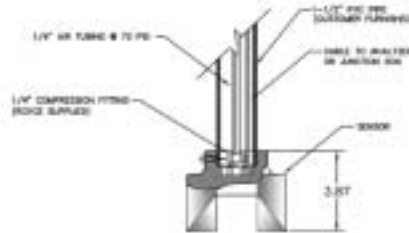
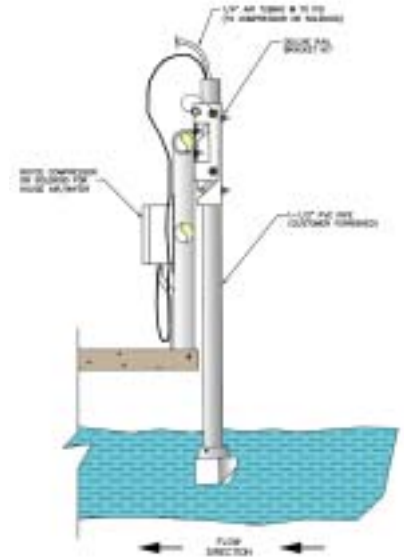

Model 72P Flow Through Low Range TSS Sensor

The **Model 72P** is a low range, flow through version of the popular Model 72A. Commonly used in outfall plumbing of packaged WWTP's, portable potable water systems, backwash filter lines and other process water lines for the measurement of low level suspended solids.



Range: 0 - 10 up to 0 - 1500 mg/l,
0 - 500 NTU

Construction: Molded Epoxy/PVC

Limits: Temp. 0 - 50° C

Pressure: 0 - 20 PSIG

Model 72P; Optical; 3" Flanged Spool Mounted; Air or Water Jet Self-Cleaning

Model 72P Sensor Mounting

- ◆ The sensor cable is a 5 conductor shielded 22 AWG. It is available in 25 and 50 foot lengths as standard, or can be special ordered as required.
- ◆ A connector for quick disconnect to the monitor is available as an optional convenience on the sensor and analyzer. The connector option on the sensor is required when used with the JB-93 junction box.
- ◆ All Royce suspended solids sensors are equipped for an air or water jet cleaning.

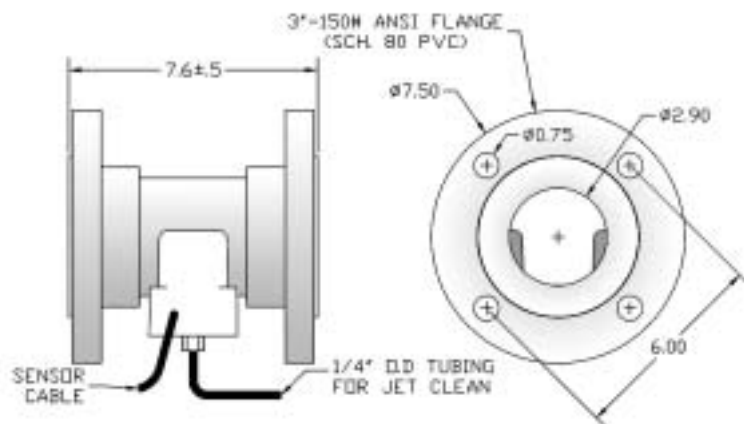

Model 73B and 75A Submersible MLSS Sensor

The **Model 73B** submersible sensor is designed for mixed liquor suspended solids or MLSS typically found in aeration basins. This sensor uses phased array color compensation to correlate light absorption with suspended solids. The **Model 75A** is designed for open channels that have a higher concentration of solids, such as return activated sludge that flows in open channels rather than in pipes

Type:

Single Gap, Optical; self cleaning. **Model 73B** has phased array emitter/receptor combination for automatic color compensation

73B Range:

0 - 3,000 up to 0 - 30,000 mg/l
0 - 3%

75A Range: (Not Phased Array):

0 - 5,000 up to 0 - 50,000 mg/l
0 - 5%

Accuracy:

73B: ± 5% of reading or ± 100 mg/l, whichever is greater
75A: ± 5% of reading or ± 150 mg/l, whichever is greater

Repeatability:

73B: ± 1% of reading or ± 20 mg/l, whichever is greater
75A: ± 1% of reading or ± 30 mg/l, whichever is greater

Operating Limits:

Temperature: 0 - 50° C
Pressure: 0 - 50 PSIG

Size:

2.5 inches diameter
3.3 inches long

Weight:

12 ounces (.34 kg)

Construction:

Chemically resistant polyurethane optics
Molded polymer housing

Sensor Mounting

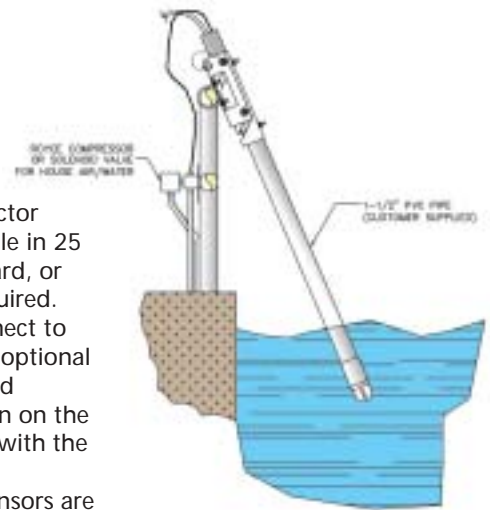

- ◆ The sensor cable is a 8 conductor shielded 22 AWG. It is available in 25 and 50 foot lengths as standard, or can be special ordered as required.
- ◆ A connector for quick disconnect to the monitor is available as an optional convenience on the sensor and analyzer. The connector option on the sensor is required when used with the **JB-93** junction box.
- ◆ All Royce suspended solids sensors are equipped for an air or water jet cleaning.

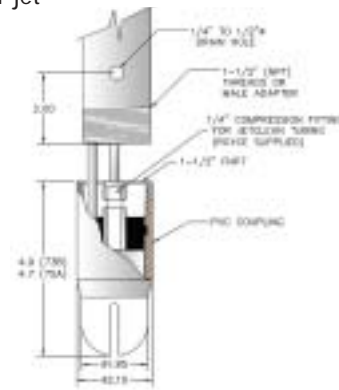

Models 73P and 75P Flow Through MLSS Sensors



The **Models 73P and 75P** in-line MLSS sensors are common for use with in-line mixed liquor applications, septic waste influent applications, and packaged WWTP RAS, WAS MLSS and influent lines.

73P

Mid-Range; Color Compensated; Pipe insertion; Air or Water Jet Self Cleaning
Range: 0 - 3,000 up to 0 - 30,000 mg/l
0 - 3%
Construction: Molded Epoxy/PVC
Limits: Temp. 0 - 50° C
Pressure: 0 - 20 PSIG

75P

Mid-Range; Optical; Pipe insertion; Air or Water Jet Self Cleaning
Range: 0 - 5,000 up to 0 - 50,000 mg/l
0 - 5%
Construction: Molded Epoxy/PVC
Limits: Temp. 0 - 50° C
Pressure: 0 - 20 PSIG

Models 73P and 75P Sensor Mounting

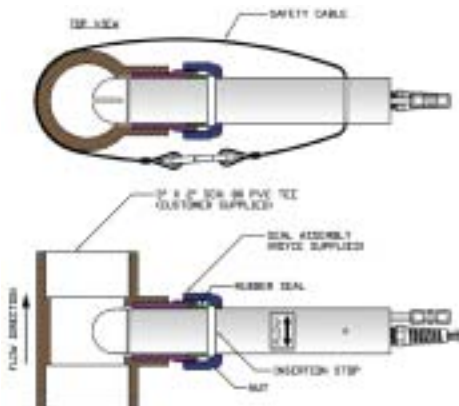

- ◆ The sensor cable is a 8 conductor shielded 22 AWG. It is available in 25 and 50 foot lengths as standard, or can be special ordered as required.
- ◆ A connector for quick disconnect to the monitor is available as an optional convenience on the sensor and analyzer. The connector option on the sensor is required when used with the **JB-93** junction box.
- ◆ All Royce suspended solids sensors are equipped for an air or water jet cleaning.

Model 74A and 76A High Density Pipe Insertion Sensors

The Model 74A and 76A in-line sensors are used in WAS (Waste Activated Sludge) and RAS (Return Activated Sludge) line applications. These sensors offer automatic water Jet cleaning of the sensor optics by house supplied water.

Type:

Single Gap, Optical; self cleaning water jet

74A Range:

0 - 8,000 up to 0 - 80,000 mg/l
0 - 8%

76A Range:

0 - 3,000 up to 0 - 30,000 mg/l
0 - 3%

Accuracy:

74A: $\pm 5\%$ of reading or ± 150 mg/l, whichever is greater

76A: $\pm 5\%$ of reading or ± 100 mg/l, whichever is greater

Repeatability:

74A: $\pm 1\%$ of reading or ± 30 mg/l, whichever is greater

76A: $\pm 1\%$ of reading or ± 30 mg/l, whichever is greater

Operating Limits:

Temperature: 0 - 50° C

Pressure: 0 - 50 PSIG

Size:

2 inch insertion diameter

19 inches long

2 inch NPT male pipe insertion nipple

Weight:

16 pounds (7 kg)

Construction:

316 SS insertion shaft and lens holders

Chemically resistant polyurethane optics



- ◆ The sensor cable is a 8 conductor shielded 22 AWG. It is available in 25 and 50 foot lengths as standard, or can be special ordered as required.
- ◆ A connector for quick disconnect to the monitor is available as an optional convenience on the sensor and analyzer. The connector option on the sensor is required when used with the JB-93 junction box.
- ◆ Cleaning connection supplied by Royce to house water is 3/8" compression fitting. Cleaning pressure must be 20 PSIG greater than line pressure
- ◆ All Royce suspended solids sensors are equipped for an air or water jet cleaning

Models 74A & 76A Outline and Mounting

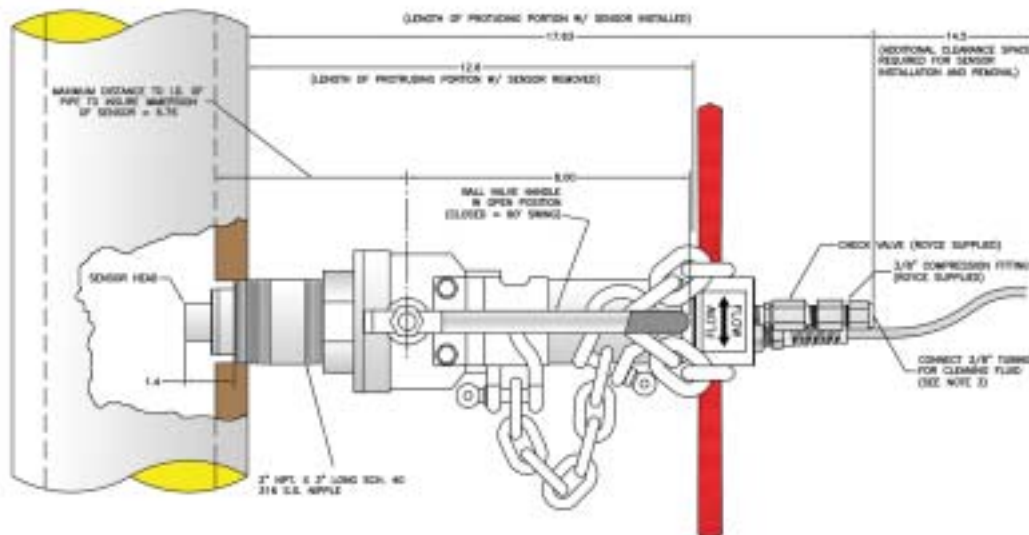

Royce JC Series Compressor Assembly For Submersible MLSS Sensor Jet Clean For Optics



**Model JC-1 Compressor
(Single Channel)**



**Model JC-4 Compressor
(Four Channel Shown)**

The sensor optics are Jet Cleaned by an air or water blast across the optics on a timed basis which is controlled by the parent instrument. Cleaning frequency and duration of the jet blast are programmed by the user to meet the demand of the application where optical surfaces are soiled by organic or biological fouling.

All Royce suspended solids sensors are equipped for Jet Cleaning of the sensor optics by house supplied air or water using a solenoid. A minimum of 30 PSIG and a maximum of 60 PSIG is required for house air or water.

The Royce Compressor Assembly is compatible with submersible MLSS sensors and is available as an option. The **Model 74A** and **76A** in-line sensors can not use the Royce Compressor Assembly.

An industrial grade high output compressor is used on all Royce JC Series compressor cleaning systems. By using the same compressor for multiple instrument sensors, the cost per sensor is drastically reduced. Any Royce analyzer can operate any JC Series compressor. In fact, a multi-channel JC-2 or JC-4 can be used on any combination of Royce dissolved oxygen, total suspended solids, or pH/ORP sensors at one time.

The Models JC 1, 2, and 4 are all available in either 115 VAC or 230 VAC versions, and all electrical parts are CE certified.

Compressor Specifications

Channels:

One, Two or Four

Compatibility:

All Royce Analyzers

Compressor Ambient Conditions:

0 to 70° C

-10 to 70° C - with optional heater

Input Power:

115 VAC, 50 - 60 Hz or 230 VAC, 50 - 60 Hz

+10% to -15%

Outputs:

Up to four, 1/4" push seal bulkhead connections

Enclosure Protection:

Vent port fitted

Enclosure:

NEMA 4X (IP65)

Enclosure Dimensions:

JC-1 - 14" W x 12" H x 6" D

JC-2 or 4 - 17.5" W x 16" H x 10.5" D

Door Hinges Up

Weight:

JC-1 - 26 lbs, 11.8 kg

JC-2 - 37 lbs, 16.8 kg

JC-4 - 40 lbs, 18.2 kg

Compressor Outline and Mounting

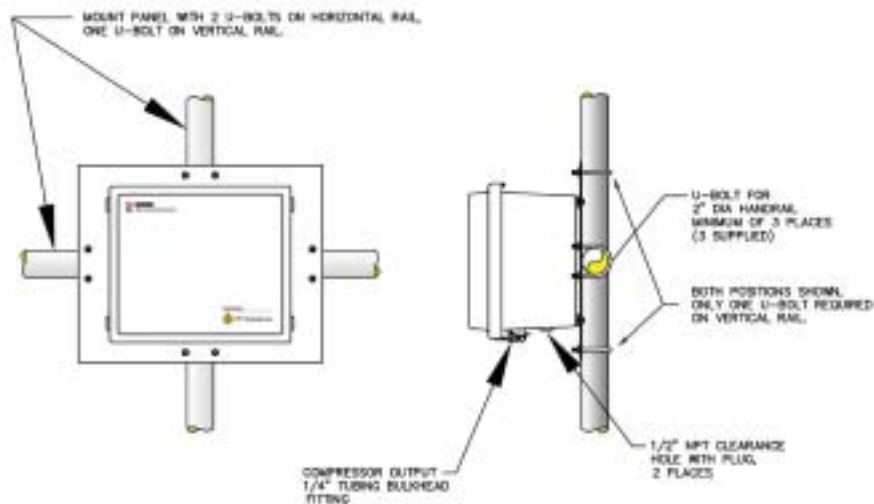

Model 711 Portable Suspended Solids and Interface Level Analyzer



Model 711 Specific Features

- ◆ **Two analyzers in one package:**
Switch from Solids measurement to Interface level without losing calibration.
- ◆ **Automatic ranging:**
Goes completely over the operating range of the analyzer with manual adjustment.
- ◆ **Simple, single button, insitu calibration**

The Royce **Model 711** Portable Suspended Solids/ Interface Level Analyzer is a rugged, waterproof instrument designed for the rigors of remote sampling. The meter provides reliable operation in waste treatment plants, rivers, lakes and other aqueous systems. The meter will read in either grams per liter when in the suspended solids mode or relative density percentage while in the interface level mode of operation.

The **Model 711** stores the calibration values for suspended solids and interface level in two separate non-volatile memory locations allowing the user to switch between operational modes without having to recalibrate. The net effect is two analyzers in one.

Due to the full utilization of the microprocessor, calibration values are stored so that recalibration is not required on a daily basis. If the sensor is cleaned after use, monthly calibration is usually more than sufficient for proper operation in either mode of calibration.

The **Model 711** analyzer utilizes the **Model 71** medium range sensor. The **Model 71** is a rugged, reliable sensing element that has polymer optical grade lenses. It was designed specifically to meet the rigorous demands that are a requirement for a portable sensor.

Model 711 / 71 Specifications

Range:

0 - 10 grams per liter (0 to 10,000 mg/l)

Readout Device:

Harsh environment, 1/2" LCD digital display

Input Power:

Standard 9V battery

Enclosure:

Waterproof

Size:

7 inches long
3.2 inches wide
1.5 inches deep

Weight:

1.5 pounds (.68 kg)

Type:

Single Gap, Optical

Accuracy: $\pm 5\%$ of reading or ± 100 mg/l, whichever is greater

Repeatability:

$\pm 1\%$ of reading or ± 20 mg/l, whichever is greater

Range:

0 - 10 g/l

Operating Limits:

Temperature, 0 - 65° C
Pressure, 0 - 50 PSIG

Size:

4 inches long
2 inches diameter

Weight:

1 pound (.45 kg)

Construction:

Polyurethane body
Optical grade polymer lenses

Supplied Standard with Model 711 System

- ◆ **Model 711** rugged Suspended Solids analyzer
- ◆ **Model 71** rugged SS sensor with 8 meters or 25 feet of cable and waterproof, military connector.
Cable is scaled in one foot increments.
- ◆ Velcro "grip strap" which can convert to a handy belt holder.
- ◆ 9V battery.
- ◆ Detailed instruction manual.

Model 7011A Analyzer Dimensions

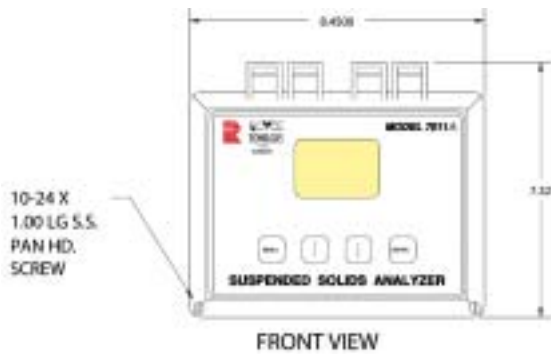

JB-93 Junction Box



Construction:
Polystyrene NEMA 4X
(IP65)

Options:
Rail Mounting Kit

Weight:
JB-93: 2 Lbs
With rail mount kit: .5 Lbs

Model 7011A Rail Kit Outline and Mounting

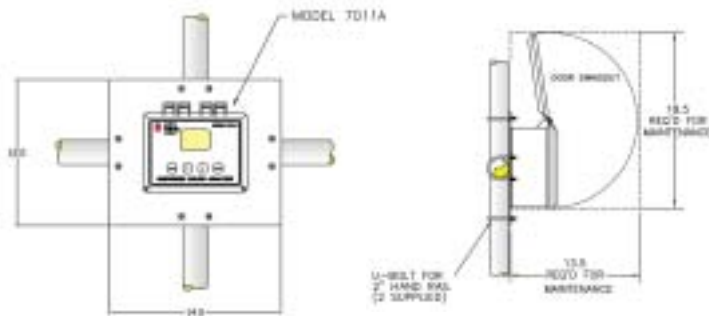

Rail Kit Outline and Mounting

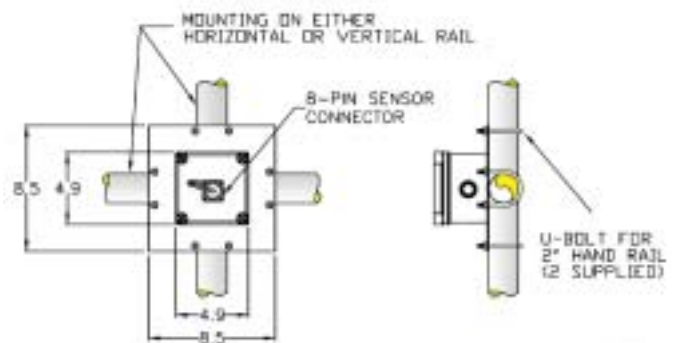

Series 7100/8000 Analyzers

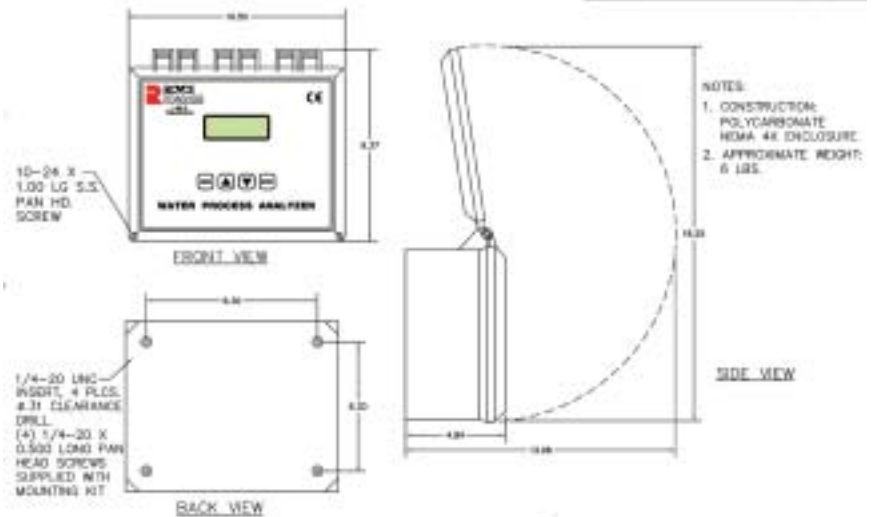
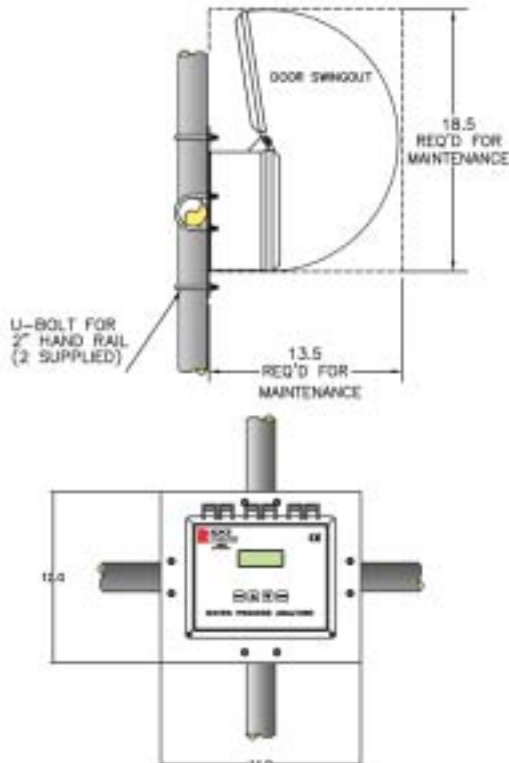

13555 Gentilly Road
New Orleans, LA 70129
800/347-3505
504/254-8888

FAX: 504/254-8855 - royce@sanitaire.itt.com
Web Site: <http://www.roycetechnologies.com>

Sanitaire

