

# Georg Fischer Type 369 Wafer Check Valve

## Standard Features

- **Size**  
1½"-12"
- **Material**  
PVC
- **Seals**  
EPDM or FPM  
Sealing with special Q ring,  
compatible with flat or serrated  
flanges
- **Spring (optional)**  
316 SS or Hastelloy C
- **Mounting**  
Suitable for vertical and horizontal  
mounting
- **Installation**  
Mounts between both ANSI and ISO/  
DIN flanges  
  
Centerin eyelets for easy fitting

## Standards

- ANSI
- ISO/DIN



## General

The 369 wafer check valve from Georg Fischer is an ideal solution for a variety of applications. Mounted between two ANSI flanges, the design of the 369 valve allows for easy installation or removal in the field. The valve is available in versions with or without springs. The spring loaded version works well in horizontal installations where many check valves may not. With the standard 316 stainless steel spring or the optional hastelloy C, the valve can be subjected to a wide range of chemical mixes. The 369 valve, with a size range of 1½" to 12", is a perfect fit for many of today's industrial applications

**Important note:** This is not a full port valve. Opening angle is between 70-90%.

# Type 369 Wafer Check Valve

## Type 369 Wafer Check Valve PVC Without Spring

Size ID Inch	PVC/EPDM	psi	PVC/FPM	lbs	Flange Size
1½	161 369 003	90	161 369 023	0.35	2
2	161 369 004	90	161 369 024	0.55	2½
2½	161 369 005	90	161 369 025	0.71	3
3	161 369 006	90	161 369 026	0.86	4
4	161 369 007	90	161 369 027	1.21	4
5	161 369 009	90	161 369 029	1.65	5
6	161 369 010	90	161 369 030	2.43	6
8	161 369 011	90	161 369 031	4.63	8
10	161 369 012	90	161 369 032	7.72	10
12	161 369 013	90	161 369 033	11.68	12

**Note:** For sizes 3" and below use next size flange adapter, see recommended flanges below

## Type 369 Wafer Check Valve SS-316 Spring PVC

Size ID Inch	PVC/EPDM	psi	PVC/FPM	lbs	Flange Size
1½	161 369 043	90	161 369 063	0.35	2
2	161 369 044	90	161 369 064	0.55	2½
2½	161 369 045	90	161 369 065	0.71	3
3	161 369 046	90	161 369 066	0.86	4
4	161 369 047	90	161 369 067	1.21	4
5	161 369 049	90	161 369 069	1.65	5
6	161 369 050	90	161 369 070	2.43	6
8	161 369 051	90	161 369 071	4.63	8
10	161 369 052	90	161 369 072	7.72	10
12	161 369 053	90	161 369 073	11.68	12

**Note:** For sizes 3" and below use next size flange adapter, see recommended flanges below

## Type 369 Wafer Check Valve Hastelloy C Spring PVC

Size ID Inch	PVC/EPDM	psi	PVC/FPM	lbs.	Flange Size
1½	161 369 083	90	161 369 103	0.35	2
2	161 369 084	90	161 369 104	0.55	2½
2½	161 369 085	90	161 369 105	0.71	3
3	161 369 086	90	161 369 106	0.86	4
4	161 369 087	90	161 369 107	1.21	4
5	161 369 089	90	161 369 109	1.65	5
6	161 369 090	90	161 369 110	2.43	6
8	161 369 091	90	161 369 111	4.63	8
10	161 369 092	90	161 369 112	7.72	10
12	161 369 093	90	161 369 113	11.68	12

**Note:** For sizes 3" and below use next size flange adapter, see recommended flanges below

## Van Stone Flange

Size ID Inch	PVC
2	856-020
2½	856-025
3	856-030
4	856-040
6	856-060
8	856-080
10	854-100
12	854-120

**Note:** Sizes 2"-8" are Spigot Ends; 10"-12" are Socket Ends

# Technical Data

## Flange Assembly, Type 369

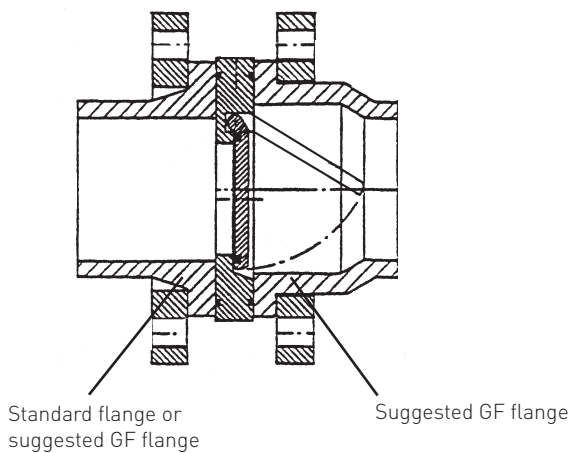

### Important Installation Instructions

- A stabilizing zone of at least 5 times nominal diameter should be provided before and after the wafer check valve
- For sizes 3" and below use the next larger flange size (i.e. 2" valves require a 2½" flange)
- Direct installation on pump flange or bend not recommended
- Wafer check valves without reset spring are not recommended for pulsating flows

### Pressure Loss

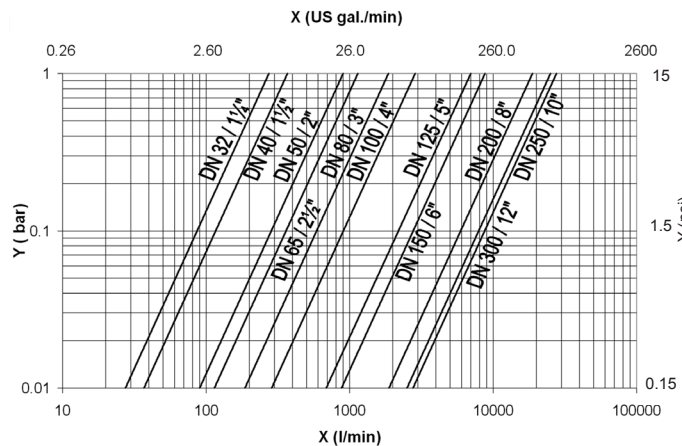

Cv Flow rate [l/min, US gal/min]  
 Y Pressure Loss  $\Delta p$  [bar, psi]

### Cv values

Inch	Cv US gal/min [ $\Delta p = 1$ psi]
1½	25.9
2	63.0
2½	79.8
3	130.9
4	200.9
5	399.0
6	483.0
8	1316.0
10	1750.0
12	1932.0

## Pressure-Temperature Diagram

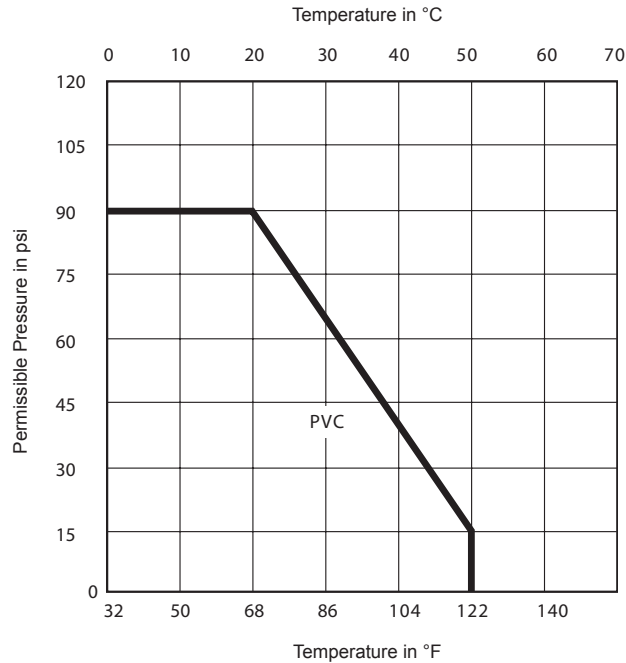

## Dimensions, opening pressure, tightness

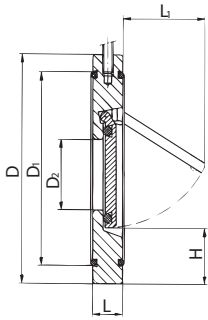

Dimensions							Opening Pressure [psi]				Minimum water column for sealing [ft.]
Inch	D [mm]	D1 [mm]	D2 [mm]	L [mm]	L1 [mm]	H [mm]	Vertical without spring	vertical with spring	horizontal without spring	horizontal with spring	PVC
1½	95	72	22	16	25	28	0.15	0.44	0.01	0.29	6.5
2	109	86	32	18	37	29	0.15	0.44	0.01	0.29	6.5
2½	129	105	40	20	50	31	0.15	0.44	0.01	0.29	6.5
3	144	119	54	20	61	32	0.15	0.44	0.01	0.29	6.5
4	164	146	70	23	77	31	0.15	0.44	0.01	0.29	6.5
5	195	173	92	23	94	35	0.15	0.44	0.01	0.29	6.5
6	220	197	112	26	115	35	0.15	0.44	0.01	0.29	6.5
8	275	255	154	35	152	38	0.26	0.55	0.01	0.29	6.5
10	330	312	192	40	180	41	0.26	0.55	0.01	0.29	6.5
12	380	363	227	45	215	41	0.26	0.55	0.01	0.29	6.5

## Dimensions, opening pressure, tightness

Inch	Number of bolts	Torque [ft. lb.]	Torque [Nm]
1½	4	8.5	12
2	4	11.1	15
2½	4	13.3	18
3	4	14.8	20
4	8	16.2	22
5	8	18.4	25
6	8	22.1	30
8	8	44.3	60
10	12	44.3	60
12	12	44.3	60