

SwitchPoint™ Remote Relay Level Controller

SwitchPoint LC40 0412 D3_0

Specifications

Supply voltage:	120/240 VAC @ 50-60 Hz.
Consumption:	5 watts max.
Sensor inputs:	LC40: (1) two-wire level switch LC41: (2) two-wire level switches LC42: (3) two-wire level switches
Sensor supply:	13.5 VDC @ 27 mA
Contact type:	LC40: (1) SPDT relay LC41: (1) SPDT relay, latching LC42: (2) SPDT relays, (one latching)
Contact rating:	250 VAC @ 10A
Contact latch:	LC40: N/a LC41/2: Select ON/OFF
Contact delay:	0-60 seconds
LED indication:	Sensor, power and relay status
Electronics temp.:	F: -40° to 158° C: -40° to 70°
Enclosure type:	35 mm DIN rail
Encl. material:	PP, UL94VO
Classification:	General purpose
Certificate:	CSA: LR 79326
CE compliance:	EN 50082-2 immunity EN 55011 emission EN 61010-1 safety



Description

The general purpose controller is offered in three versions with 1 or 2 relays and 1-3 sensor inputs. The LC40 provides a high or low level switch with a single sensor input. The LC41 provides latched automatic fill or empty control with two sensor inputs. The LC42 provides latched automatic fill or empty control and an independent high or low level switch with three sensor inputs. Package the controller with any of our level switches. The controller measures the level switch current consumption via a two-wire loop and may be located up to 1000' from the sensor. It's level made simple!

Features

- ✓ LED indicators provide user with power, sensor and relay status
- ✓ Fail-safe relay control of pumps and valves with 0-60 second time delay
- ✓ PP 35 mm DIN enclosure with removable terminal strips

Switch-Point Ordering

LC4 -1001

Contact(s) / input(s) (1) (2) (3) (4)

- 0 1 SPDT relay / 1 sensor
- 1 1 SPDT latching relay / 2 sensors
- 2 2 SPDT relays (1 latching) / 3 sensors



Ordering Notes

- 1) Select the best configuration based upon your control requirements. The following are the typical applications for each type:
LC40: High or low level switch
LC41: Automatic fill or empty
LC42: Automatic fill or empty with high or low level switch
- 2) To factory configure for 240 VAC, place an E at the end of the P/N: (ie: LC40-1001-E).
- 3) For field mount installation in a NEMA 4X polycarbonate windowed enclosure, order the LM94-1001 (single controller box) or the LM95-1001 (two controller box).
- 4) To order the CE configuration, place CE at the end of the P/N: (ie: LC42-1001-CE).

SwitchPoint™ Remote Relay Level Controller

Side View

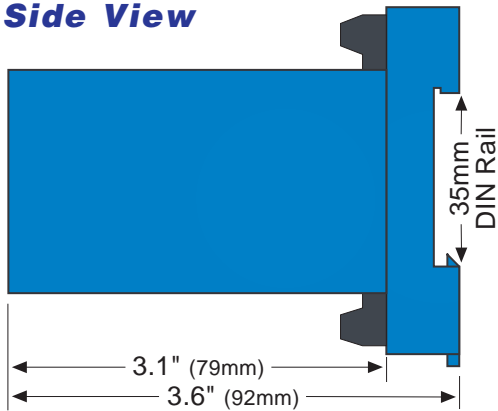

Front View

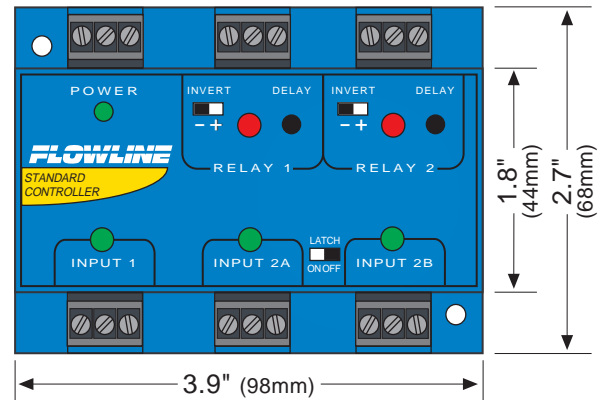

Specifications are subject to change without notice.

Wiring to a Powered Switch

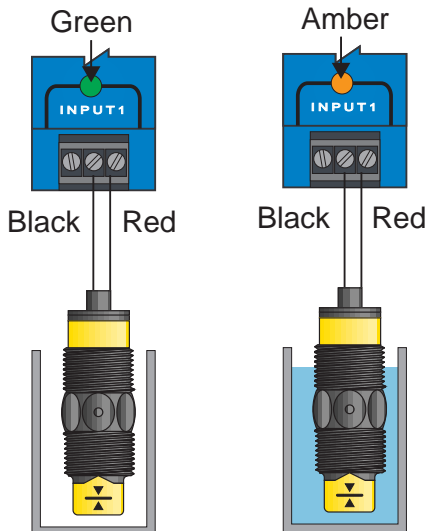

Wiring to a Mechanical Switch

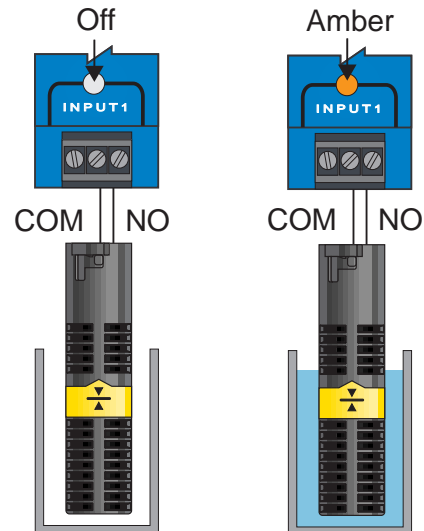

High Level Alarm

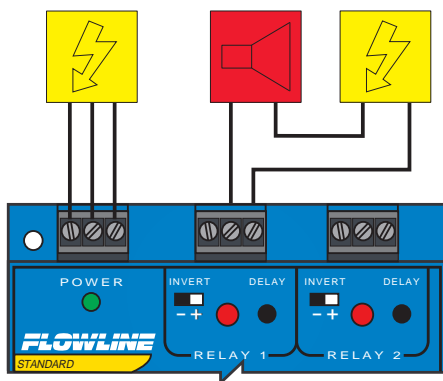

Auto Fill

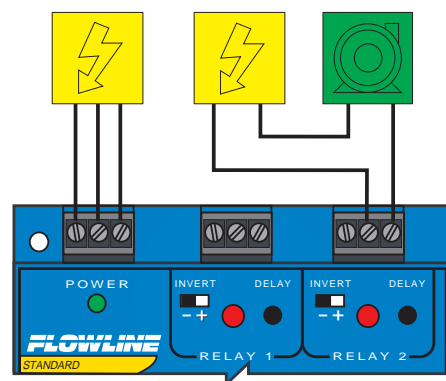

Warning: The use of an appropriate motor starter or secondary relay is recommended with pumps, valves or alarms to prevent damage to the relay contacts. The use of suppressors (snubbers) is strictly recommended when switching inductive loads.