

# Diaphragm Valve Type 314

## Standard Features

- **Size**  
1/2" - 2"
- **Valve Body Material**  
PVC, CPVC, PROGEF Standard  
Polypropylene, SYGEF PVDF, ABS
- **Diaphragm Material**  
EPDM, PTFE, FPM, NBR, or Hypalon
- **Union O-ring (static)**  
EPDM or FPM
- **Connection**  
Socket union in PVC, CPVC, PP, PVDF, ABS  
Spigot union in PP, PVDF, CPVC
- **Pressure rating**  
150 PSI
- **Compact design**
- **Lightweight**
- **Easy replacement of diaphragm**

## Optional Features

- **Pneumatic actuation**
- **Lockable handle**
- **Connection**  
Flanged connection  
Spigot connection without union (PP, CPVC, PVDF)



## General

The Type 314 diaphragm valve incorporates a robust design with several options for wetted materials. Diaphragms are available in EPDM, PTFE, FPM, NBR, or Hypalon. The valve body is available in PVC, CPVC, PP, PVDF and ABS, allowing the valve to handle most chemical applications. In addition to being chemically resistant, the GF diaphragm valves are often the best solution for applications where particulates are present. The union design allows for easy service or replacement in the field.

# Diaphragm Valve Type 314

## Pressure-Temperature Diagrams

The following pressure temperature diagrams are based on a lifetime of 25 years and the medium water or similar media.

**Remark:** At temperatures below 0°C, please check the torque of the bolts of the membrane according to the recommended values after the system is in use.

### ABS

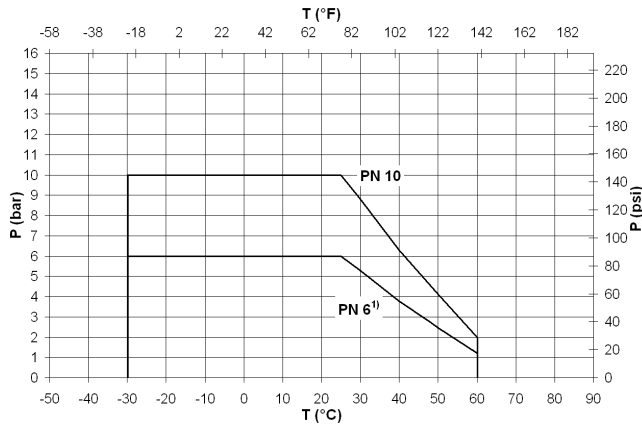

- 1) 4" and 6" flanged
- p Permissible pressure in bar, psi
- T Temperature in °C, °F

### PP

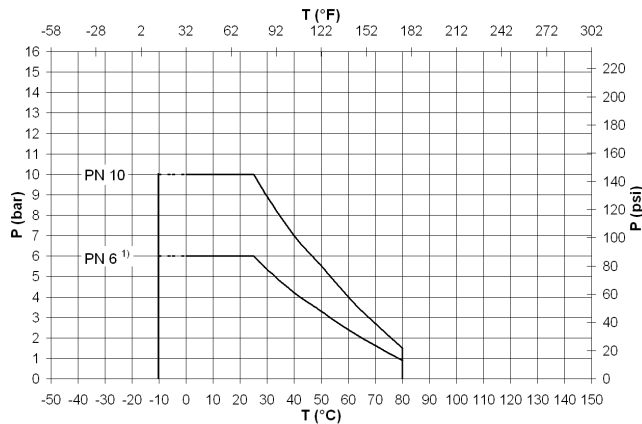

- 1) 4" and 6" flanged
- p Permissible pressure in bar, psi
- T Temperature in °C, °F

In case of applications with temperatures in the range of the dotted lines, please contact your GF representative.

### PVC

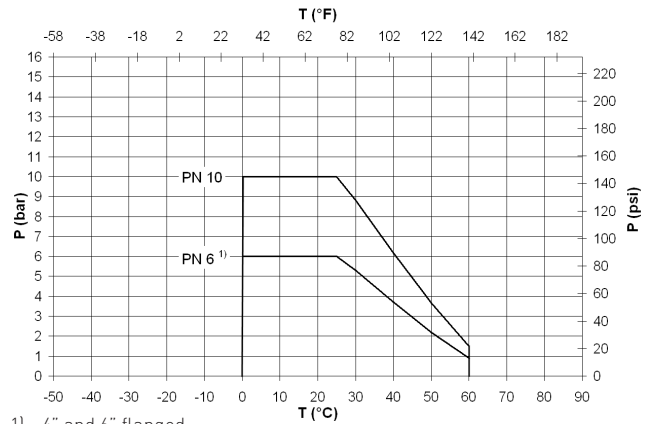

- 1) 4" and 6" flanged
- p Permissible pressure in bar, psi
- T Temperature in °C, °F

### CPVC

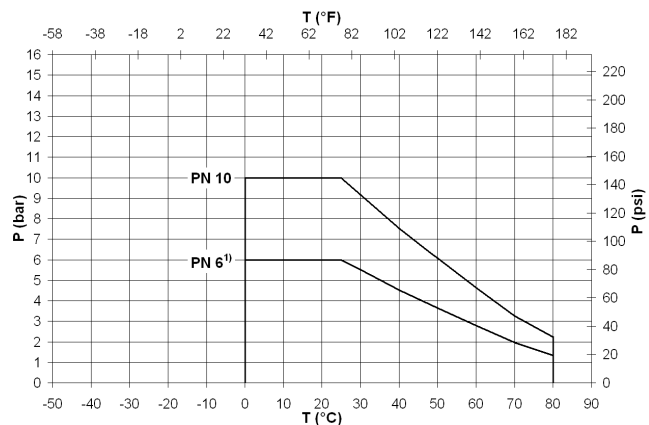

- 1) 4" and 6" flanged
- p Permissible pressure in bar, psi
- T Temperature in °C, °F

### PVDF

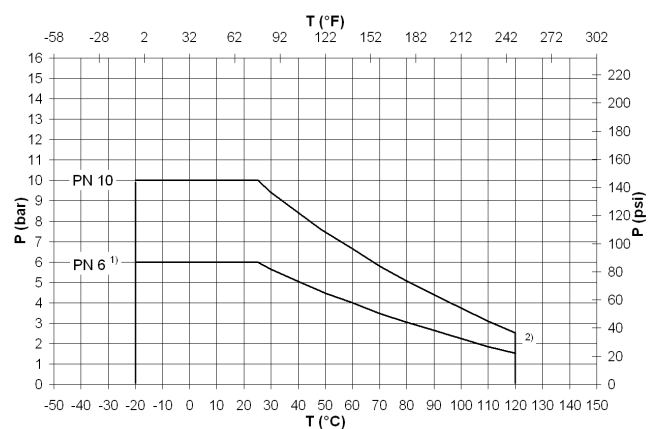

- 1) 4" and 6" flanged
- p Permissible pressure in bar, psi
- T Temperature in °C, °F

# Diaphragm Valve Type 314

## Technical Data

### Operating Torque (average values)

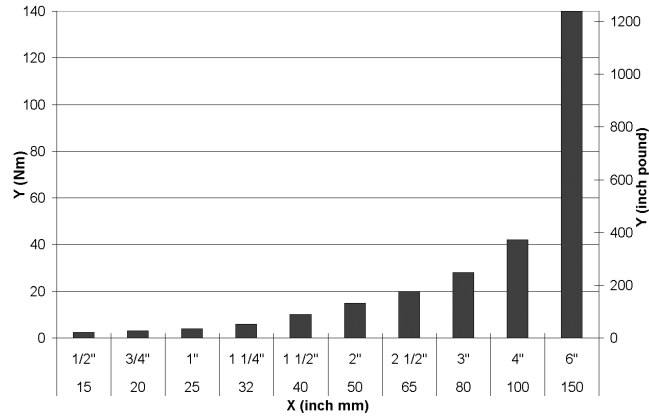

X Size DN (mm, inch)  
Y Torque (Nm, inch pound)

### Flow Characteristics

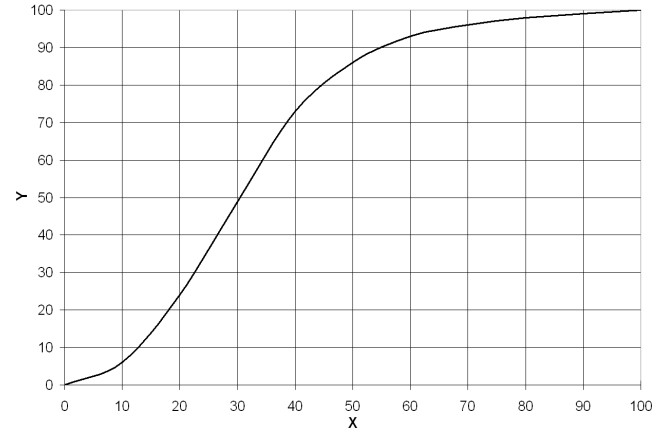

X Lift (%)  
Y Flow factor kv, cv (%)

### Pressure Loss

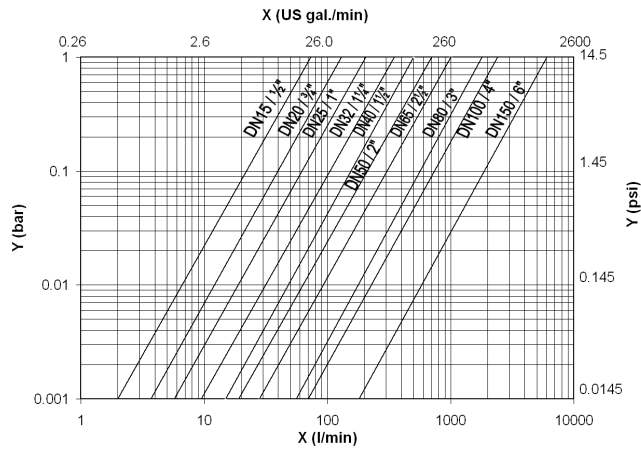

X Flow rate (l/min, US gal/min)  
Y Pressure loss  $\Delta p$  (bar, psi)

### Cv Values

The Cv values for each intermediate valve position can be determined using the flow value characteristic and the Cv values.

DN inch	d mm	kv 100 l/min ( $\Delta p=1$ bar)	Cv US gal/min ( $\Delta p=1$ psi)	kv 100 m <sup>3</sup> /h ( $\Delta p=1$ bar)
1/2	20	72	5.0	4.3
3/4	25	137	9.6	8.2
1	32	207	14.5	12.4
1 1/4	40	354	24.8	21.2
1 1/2	50	517	36.2	31.0
2	63	713	49.9	42.8

## Dimensions for Type 314 True Union Diaphragm Valve PVC (solvent cement socket ends)

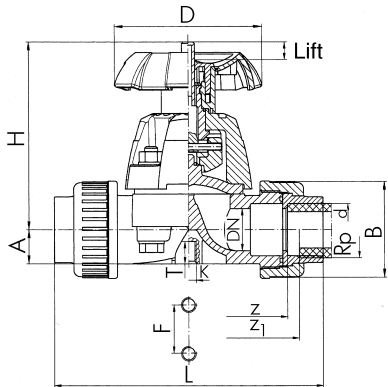

Inch size	A inch	B inch	D inch	F inch	K mm	H inch	L inch	T inch	Z inch	Lift inch	Weight lbs.
1/2	0.55	1.69	3.15	0.98	M6	3.54	5.35	.47	3.78	0.32	0.88
3/4	0.69	2.09	3.15	0.98	M6	4.02	6.30	.47	4.49	0.43	1.32
1	0.83	2.36	3.70	0.98	M6	4.67	6.93	.47	4.80	0.51	1.98
1 1/4	1.00	2.91	4.61	1.77	M8	4.96	7.80	.59	5.51	0.63	2.65
1 1/2	1.28	3.27	4.61	1.77	M8	5.47	9.13	.59	6.30	0.83	3.53
2	1.54	4.06	5.98	1.77	M8	6.77	10.55	.59	7.48	1.10	6.17

## Polypropylene and SYGEF-PVDF (IR-Butt, socket and BCF fusion ends)

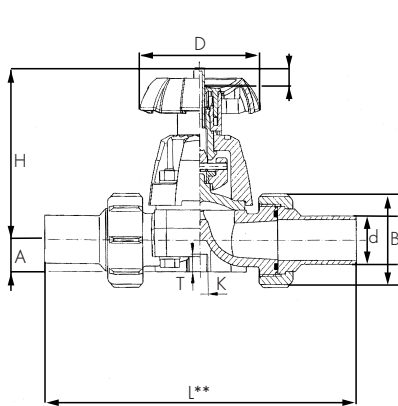

IR/butt fusion end connections

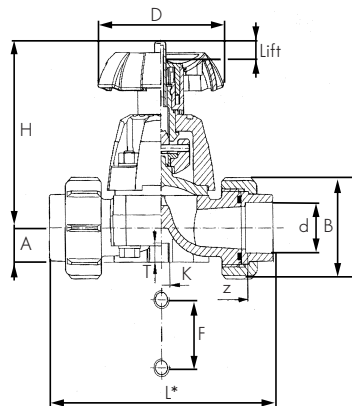

socket fusion end connections

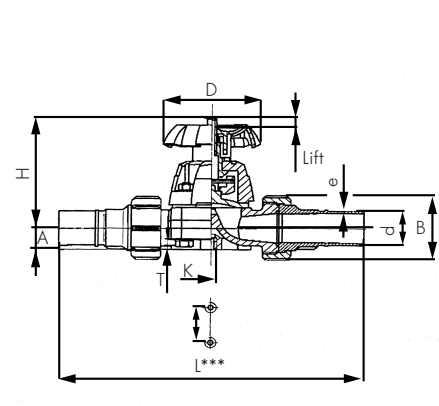

BCF fusion end connections

Metric size d mm	e PP mm	e PVDF mm	A inch	B inch	D inch	F inch	H inch	K mm	L* inch	L** PP inch	L** PVDF inch	T PP inch	T PVDF inch	z inch	Lift inch
20	1.7	1.9	0.55	1.77	1.85	0.98	3.54	M6	5.04	7.72	7.72	0.47	0.49	3.94	0.31
25	2.3	1.9	0.69	2.17	2.24	0.98	3.98	M6	5.91	8.70	8.66	0.47	0.49	4.65	0.43
32	3.0	2.4	0.85	2.44	2.52	0.98	4.61	M6	6.38	9.21	9.21	0.47	0.49	4.96	0.51
40	3.7	2.4	1.00	2.95	3.07	1.77	5.00	M6	7.24	10.24	10.16	0.59	0.49	5.67	0.63
50	4.6	3.0	1.26	3.29	3.50	1.77	5.47	M6	8.27	11.18	11.18	0.59	0.49	6.46	0.83
63	5.8	3.0	1.54	3.98	4.29	1.77	6.77	M6	9.76	12.64	12.60	0.59	0.49	7.64	1.10

Metric size d mm	Weight* PP lbs.	Weight** PP lbs.	Weight* PVDF lbs.	Weight** PVDF lbs.
20	0.904	0.93	1.04	1.08
25	1.279	1.32	1.52	1.57
32	1.742	1.79	2.07	2.14
40	2.734	2.80	3.31	3.42
50	3.527	3.64	4.32	4.50
63	6.261	6.48	7.52	7.80

\* socket fusion

\*\* IR/butt fusion / Plus BCF

# GF Piping Systems → worldwide at home

Our sales companies and representatives ensure local customer support in over 100 countries.

[www.piping.georgfischer.com](http://www.piping.georgfischer.com)



The technical data is not binding. They neither constitute expressly warranted characteristics nor guaranteed properties nor a guaranteed durability. They are subject to modification. Our General Terms of Sale apply.

## Adding Quality to People's Lives

### Australia

George Fischer Pty Ltd  
Riverwood NSW 2210 Australia  
Phone +61(0)2 9502 8000  
[australia.ps@georgfischer.com](mailto:australia.ps@georgfischer.com)  
[www.georgfischer.com.au](http://www.georgfischer.com.au)

### Austria

Georg Fischer  
Rohrleitungssysteme GmbH  
3130 Herzogenburg  
Phone +43(0)2782 856 43-0  
[austria.ps@georgfischer.com](mailto:austria.ps@georgfischer.com)  
[www.georgfischer.at](http://www.georgfischer.at)

### Belgium/Luxembourg

Georg Fischer NV/SA  
1070 Bruxelles/Brüssel  
Phone +32(0)2 556 40 20  
[be.ps@georgfischer.com](mailto:be.ps@georgfischer.com)  
[www.georgfischer.be](http://www.georgfischer.be)

### Brazil

George Fischer Ltda  
04795-100 São Paulo  
Phone +55(0)11 5687 1311  
[br.ps@georgfischer.com](mailto:br.ps@georgfischer.com)

### Canada

Georg Fischer Piping Systems Ltd  
Brampton, ON L6T 4E3  
Phone +1(905) 792-8005  
[ca.ps@georgfischer.com](mailto:ca.ps@georgfischer.com)  
[www.gf.piping.ca](http://www.gf.piping.ca)

### China

Georg Fischer  
Piping Systems Ltd Shanghai  
Pudong, Shanghai 201319  
Phone +86(0)21 58 13 33 33  
[china.ps@georgfischer.com](mailto:china.ps@georgfischer.com)  
[www.cn.piping.georgfischer.com](http://www.cn.piping.georgfischer.com)

### Denmark/Iceland

Georg Fischer A/S  
2630 Taastrup  
Phone +45 (0)70 22 19 75  
[info.dk.ps@georgfischer.com](mailto:info.dk.ps@georgfischer.com)  
[www.georgfischer.dk](http://www.georgfischer.dk)

### France

Georg Fischer SAS  
95932 Roissy Charles de Gaulle Cedex  
Phone +33(0)1 41 84 68 84  
[fr.ps@georgfischer.com](mailto:fr.ps@georgfischer.com)  
[www.georgfischer.fr](http://www.georgfischer.fr)

### Germany

Georg Fischer GmbH  
73095 Albershausen  
Phone +49(0)7161 302-0  
[info.de.ps@georgfischer.com](mailto:info.de.ps@georgfischer.com)  
[www.georgfischer.de](http://www.georgfischer.de)

### India

Georg Fischer Piping Systems Ltd  
400 076 Mumbai  
Phone +91 224007 2001  
[in.ps@georgfischer.com](mailto:in.ps@georgfischer.com)  
[www.georgfischer.in](http://www.georgfischer.in)

### Italy

Georg Fischer S.p.A.  
20063 Cernusco S/N (MI)  
Phone +3902 921 861  
[it.ps@georgfischer.com](mailto:it.ps@georgfischer.com)  
[www.georgfischer.it](http://www.georgfischer.it)

### Japan

Georg Fischer Ltd  
556-0011 Osaka,  
Phone +81(0)6 6635 2691  
[jp.ps@georgfischer.com](mailto:jp.ps@georgfischer.com)  
[www.georgfischer.jp](http://www.georgfischer.jp)

### Korea

Georg Fischer Piping Systems  
Guro-3 dong, Guro-gu, Seoul, Korea  
Phone +82(0)2 2081 1450  
Fax +82(0)2 2081 1453  
[kor.ps@georgfischer.com](mailto:kor.ps@georgfischer.com)

### Malaysia

Georg Fischer (M) Sdn. Bhd.  
40460 Shah Alam, Selangor  
Phone +60 (0)3 5122 5585  
[conne.kong@georgfischer.com](mailto:conne.kong@georgfischer.com)

### Mexico

Georg Fischer S.A. de C.V.  
Apodaca, Nuevo Leon  
CP66636 Mexico  
Phone +52 (81)1340 8586  
Fax +52 (81)1522 8906

### Middle East

Georg Fischer Piping Systems  
Dubai, United Arab Emirates  
Phone +971 4 289 49 60  
[info.export@georgfischer.com](mailto:info.export@georgfischer.com)  
[www.export.georgfischer.com](http://www.export.georgfischer.com)

### Netherlands

Georg Fischer N.V.  
8161 PA Epe  
Phone +31(0)578 678 222  
[nl.ps@georgfischer.com](mailto:nl.ps@georgfischer.com)  
[www.georgfischer.nl](http://www.georgfischer.nl)

### Norway

Georg Fischer AS  
1351 Rud  
Phone +47(0)67 18 29 00  
[no.ps@georgfischer.com](mailto:no.ps@georgfischer.com)  
[www.georgfischer.no](http://www.georgfischer.no)

### Poland

Georg Fischer Sp. z o.o.  
02-226 Warszawa  
Phone +48(0)22 313 10 50  
[poland.ps@georgfischer.com](mailto:poland.ps@georgfischer.com)  
[www.georgfischer.pl](http://www.georgfischer.pl)

### Romania

Georg Fischer  
Piping Systems Ltd  
020257 Bucharest - Sector 2  
Phone +40(0)21 230 53 80  
[ro.ps@georgfischer.com](mailto:ro.ps@georgfischer.com)  
[www.export.georgfischer.com](http://www.export.georgfischer.com)

### Russia

Georg Fischer Piping Systems  
Moscow 125047  
Tel. +7 495 258 60 80  
[ru.ps@georgfischer.com](mailto:ru.ps@georgfischer.com)  
[www.georgfischer.ru](http://www.georgfischer.ru)

### Singapore

George Fischer Pte Ltd  
528 872 Singapore  
Phone +65(0)67 47 06 11  
[spp.ps@georgfischer.com](mailto:spp.ps@georgfischer.com)  
[www.georgfischer.com.sg](http://www.georgfischer.com.sg)

### Spain/Portugal

Georg Fischer S.A.  
28046 Madrid  
Phone +34(0)91 781 98 90  
[es.ps@georgfischer.com](mailto:es.ps@georgfischer.com)  
[www.georgfischer.es](http://www.georgfischer.es)

### Sweden/Finland

Georg Fischer AB  
12523 Älvsjö-Stockholm  
Phone +46(0)8 506 775 00  
[info.se.ps@georgfischer.com](mailto:info.se.ps@georgfischer.com)  
[www.georgfischer.se](http://www.georgfischer.se)

### Switzerland

Georg Fischer  
Rohrleitungssysteme (Schweiz) AG  
8201 Schaffhausen  
Phone +41(0)52 631 30 26  
[ch.ps@georgfischer.com](mailto:ch.ps@georgfischer.com)  
[www.piping.georgfischer.ch](http://www.piping.georgfischer.ch)

### Taiwan

Georg Fischer Piping Systems  
San Chung City, Taipei Hsien  
Phone +886 2 8512 2822  
Fax +886 2 8512 2823

### United Kingdom/Ireland

George Fischer Sales Limited  
Coventry, CV2 2ST  
Phone +44(0)2476 535 535  
[uk.ps@georgfischer.com](mailto:uk.ps@georgfischer.com)  
[www.georgfischer.co.uk](http://www.georgfischer.co.uk)

### USA/Latin America/Caribbean

Georg Fischer LLC  
Tustin, CA 92780-7258  
Phone +1(714) 731 88 00  
Toll Free 800 854 40 90  
[us.ps@georgfischer.com](mailto:us.ps@georgfischer.com)  
[www.us.piping.georgfischer.com](http://www.us.piping.georgfischer.com)